

The Aurora 750 switch installation guide

The Aurora 750 switch installation guide

Table of Contents

1. Introduction	1
1.1. Conventions	2
1.2. Safety and Regulatory Information	3
1.2.1. Important Safety Instructions	3
1.2.2. FCC Title 47 CFR, Part 15:2015, Subpart B, Class A	3
1.2.3. CE Mark	4
1.2.4. Laser Safety	4
1.2.5. Power Cord Safety	5
1.2.6. Warnings and Cautionary Messages	7
1.3. Disclaimer	10
2. Hardware Installation	11
2.1. Package content	12
2.2. Installation Guidelines	13
2.3. Power and Battery Safety	14
2.3.1. Replacing a PSU	14
2.4. Grounding the Switch	16
2.5. Connect the Power Cable	17
2.6. Rack-mount Safety Precautions	18
2.7. Installation into a Rack	19
2.8. Installing Transceivers and cables into the Switch Ports	21
2.8.1. SFP+/SFP28 Port Connection (LC Type Connector)	21
2.8.2. QSFP+/QSFP28 Port Connection	22
2.9. Fan Modules	23
2.10. Console port	24
2.11. Verifying Switch Operation	25
3. Netberg Aurora 750 switch	26
3.1. Specification	28
3.2. Supported Cables and Transceivers	30

List of Figures

2.1. Removing the PSU module	15
2.2. Inserting the PSU module	15
2.3. Front brackets installation	19
2.4. Rack installation	20
2.5. Transceivers and cables	21
3.1. Aurora 750 front view	26
3.2. Aurora 750 rear view	27

List of Tables

2.1. Console cable pin definition	24
3.1. Front panel features	26
3.2. Rear panel features	27

Chapter 1. Introduction

This guide is to assist the reader with the most basic form of installation and cable connection to our switches. As there is more than one switch in the Aurora series, the actual port placement might slightly differ, however, the installation and connection logic are the same for all Netberg switches.

1.1. Conventions

Several different typographic conventions are used throughout this manual. Refer to the following examples for common usage.

Bold type face denotes menu items, buttons and application names.

Italic type face denotes references to other sections, and the names of the folders, menus, programs, and files.

<Enter> type face denotes keyboard keys.



Warning information appears before the text it references and should not be ignored as the content may prevent damage to the device.



CAUTIONS APPEAR BEFORE THE TEXT IT REFERENCES, SIMILAR TO NOTES AND WARNINGS. CAUTIONS, HOWEVER, APPEAR IN CAPITAL LETTERS AND CONTAIN VITAL HEALTH AND SAFETY INFORMATION.



Indicates information that is important to know for the proper completion of a procedure, choice of an option, or completing a task.



Highlights general or useful information and tips.

1.2. Safety and Regulatory Information

1.2.1. Important Safety Instructions

Read all caution and safety statements in this document before performing any of the instructions.

Warnings

Heed safety instructions: Before working with the switch, whether using this manual or any other resource as a reference, pay close attention to the safety instructions. Adhere to the assembly instructions in this manual to ensure and maintain compliance with existing product certifications and approvals. Use only the described, regulated components specified in this manual. Use of other products / components will void the UL listing and other regulatory approvals of the product and will most likely result in non-compliance with product regulations in the region(s) in which the product is sold.

System power on/off: The power button DOES NOT turn off the system AC power. To remove power from system, you must unplug the AC power cord from the wall outlet. Make sure the AC power cord is unplugged before opening the chassis, adding, or removing any components.

Hazardous conditions, devices and cables: Hazardous electrical conditions may be present on power, telephone, and communication cables. Turn off the switch and disconnect the power cord, telecommunications systems, networks, and modems attached to the switch before opening it. Otherwise, personal injury or equipment damage can result.

Electrostatic discharge (ESD) and ESD protection: ESD can damage transceivers, boards, and other parts. We recommend that you perform all procedures in this chapter only at an ESD workstation. If one is not available, provide some ESD protection by wearing an antistatic wrist strap attached to chassis ground any unpainted metal surface on the switch when handling parts.

1.2.2. FCC Title 47 CFR, Part 15:2015, Subpart B, Class A

This equipment has been tested and found to comply with the limits for a Class A digital device, pursuant to part 15 of the FCC Rules. These limits are designed to provide reasonable protection against harmful interference when the equipment is operated in a commercial environment. This equipment generates, uses, and can radiate radio frequency energy and, if not installed and used in accordance with the instruction manual, may cause harmful interference to radio communications. Operation of this equipment in a residential area is likely to cause harmful interference in which case the user will be required to correct the interference at his own expense.

You are cautioned that changes or modifications not expressly approved by the party responsible for compliance could void your authority to operate the equipment.

You may use unshielded twisted-pair (UTP) for RJ-45 connections - Category 3 or better for 10 Mbps connections, Category 5 or better for 100 Mbps connections, Category 5, 5e, or 6 for 1000 Mbps connections. For fiber optic connections, you may use 50/125 or 62.5/125 micron multimode fiber or 9/125 micron single-mode fiber.

1.2.3. CE Mark

CE Mark Declaration of Conformance for EMI and Safety (EEC) This information technology equipment complies with the requirements of the Council Directive 2014/30/EU on the Approximation of the laws of the Member States relating to Electromagnetic Compatibility and 2014/35/EU for electrical equipment used within certain voltage limits. For the evaluation of the compliance with these Directives, the following standards were applied: RFI Emission:

- Limit according to EN 55032:2015+AC:2016, Class A *Limit for harmonic current emission according to EN 61000-3-2:2014, Class A
- Limitation of voltage fluctuation and flicker in low-voltage supply systems according to EN 61000-3-3:2013

Immunity:

- Product family standard according to EN 55024:2010+A1:2015
- Electrostatic Discharge according to IEC 61000-4-2:2008 ED. 2.0
- Radio-frequency electromagnetic field according to IEC 61000-4-3:2010 ED. 3.2
- Electrical fast transient/burst according to IEC 61000-4-4:2012 ED. 3.0
- Surge immunity test according to IEC 61000-4-5:2014 ED. 3.0
- Immunity to conducted disturbances, Induced by radiofrequency fields: IEC 61000-4-6:2013 ED. 4.0
- Power frequency magnetic field immunity test according to IEC 61000-4-8:2009 ED. 2.0
- Voltage dips, short interruptions and voltage variations immunity test according to IEC 61000-4-11:2004 ED. 2.0

LVD: * EN 60950-1:2006+A11:2009+A1:2010+A12:2011+A2:2013

1.2.4. Laser Safety



Fiber Optic Port Safety:

CLASS 1 LASER PRODUCT: When using a fiber optic port, never look at the transmit laser while it is powered on. Also, never look directly at the fiber TX port and fiber cable ends when they are powered on.



Ports pour fibres optiques - sécurité sur le plan optique:

PRODUIT LASER DE CLASSE 1: Ne regardez jamais le laser tant qu'il est sous tension. Ne regardez jamais directement le port TX (Transmission) à fibres optiques et les embouts de câbles à fibres optiques tant qu'ils sont sous tension.



Faseroptikanschlüsse - Optische Sicherheit:

LASERPRODUKT DER KLASSE 1: Niemals ein Übertragungslaser betrachten, während dieses eingeschaltet ist. Niemals direkt auf den Faser-TX-Anschluß und auf die Faserkabelenden schauen, während diese eingeschaltet sind.

1.2.5. Power Cord Safety

Please read the following safety information carefully before installing the switch:



Installation and removal of the unit must be carried out by qualified personnel only.

- The unit must be connected to an earthed (grounded) outlet to comply with international safety standards.
- Do not connect the unit to an A.C. outlet (power supply) without an earth (ground) connection.
- The appliance coupler (the connector to the unit and not the wall plug) must have a configuration for mating with an EN 60320/IEC 320 appliance inlet.
- The socket outlet must be near to the unit and easily accessible. You can only remove power from the unit by disconnecting the power cord from the outlet.
- This unit operates under SELV (Safety Extra Low Voltage) conditions according to IEC 60950. The conditions are only maintained if the equipment to which it is connected also operates under SELV conditions.

France and Peru only

This unit cannot be powered from IT[†] supplies. If your supplies are of IT type, this unit must be powered by 230 V (2P+T) via an isolation transformer ratio 1:1, with the secondary connection point labelled Neutral, connected directly to earth (ground).



Before making connections, make sure you have the correct cord set. Check it (read the label on the cable) against the following:

Power Cord Set	
U.S.A. and Canada	<p>The cord set must be UL-approved and CSA certified.</p> <p>The minimum specifications for the flexible cord are:</p> <ul style="list-style-type: none"> • No. 18 AWG - not longer than 2 meters, or 16 AWG. • Type SV or SJ • 3-conductor <p>The cord set must have a rated current capacity of at least 10 A</p>

Power Cord Set	
	The attachment plug must be an earth-grounding type with NEMA 5-15P (15 A, 125 V) configuration.
Denmark	The supply plug must comply with Section 107-2-D1, Standard DK2-1a or DK2-5a.
Switzerland	The supply plug must comply with SEV/ASE 1011.
U.K.	The supply plug must comply with BS1363 (3-pin 13 A) and be fitted with a 5 A fuse which complies with BS1362. The mains cord must comply with IEC 60227 (designation 60227 IEC 52).
Europe	The supply plug must comply with CEE7/7 ("SCHUKO"). The mains cord must comply with IEC 60227 (designation 60227 IEC 52).

Veuillez lire à fond l'information de la sécurité suivante avant d'installer le Switch:



L'installation et la dépose de ce groupe doivent être confiés à un personnel qualifié.

- Ne branchez pas votre appareil sur une prise secteur (alimentation électrique) lorsqu'il n'y a pas de connexion de mise à la terre (mise à la masse).
- Vous devez raccorder ce groupe à une sortie mise à la terre (mise à la masse) afin de respecter les normes internationales de sécurité.
- Le coupleur d'appareil (le connecteur du groupe et non pas la prise murale) doit respecter une configuration qui permet un branchement sur une entrée d'appareil EN 60320/IEC 320.
- La prise secteur doit se trouver à proximité de l'appareil et son accès doit être facile. Vous ne pouvez mettre l'appareil hors circuit qu'en débranchant son cordon électrique au niveau de cette prise.
- L'appareil fonctionne à une tension extrêmement basse de sécurité qui est conforme à la norme IEC 60950. Ces conditions ne sont maintenues que si l'équipement auquel il est raccordé fonctionne dans les mêmes conditions.

France et Pérou uniquement:

Ce groupe ne peut pas être alimenté par un dispositif à impédance à la terre. Si vos alimentations sont du type impédance à la terre, ce groupe doit être alimenté par une tension de 230 V (2 P+T) par le biais d'un transformateur d'isolement à rapport 1:1, avec un point secondaire de connexion portant l'appellation Neutre et avec raccordement direct à la terre (masse).

Cordon électrique - Il doit être agréé dans le pays d'utilisation	
Etats-Unis et Canada:	<p>Le cordon doit avoir reçu l'homologation des UL et un certificat de la CSA.</p> <p>Les spécifications minimales pour un câble flexible sont AWG No. 18, ou AWG No. 16 pour un câble de longueur inférieure à 2 mètres.</p> <ul style="list-style-type: none"> • type SV ou SJ • 3 conducteurs

Cordon électrique - Il doit être agréé dans le pays d'utilisation	
	Le cordon doit être en mesure d'acheminer un courant nominal d'au moins 10 A. La prise femelle de branchement doit être du type à mise à la terre (mise à la masse) et respecter la configuration NEMA 5-15P (15 A, 125 V).
Danemark:	La prise mâle d'alimentation doit respecter la section 107-2 D1 de la norme DK2 1a ou DK2 5a.
Suisse:	La prise mâle d'alimentation doit respecter la norme SEV/ ASE 1011.
Europe	La prise secteur doit être conforme aux normes CEE 7/7 ("SCHUKO") Le cordon d'alimentation doit être conforme à la norme IEC 60227 (IEC 60227 désignation 52)

1.2.6. Warnings and Cautionary Messages



This product does not contain any serviceable user parts.



Installation and removal of the unit must be carried out by qualified personnel only.



When connecting this device to a power outlet, connect the field ground lead on the tri-pole power plug to a valid earth ground line to prevent electrical hazards.



This switch uses lasers to transmit signals over fiber optic cable. The lasers are compliant with the requirements of a Class 1 Laser Product and are inherently eye safe in normal operation. However, you should never look directly at a transmit port when it is powered on.



When selecting a fiber SFP+/QSFP28 device, considering safety, please make sure that it can function at a temperature that is not less than the recommended maximum operational temperature of the product. You must also use an approved Laser Class 1 SFP+/QSFP28 transceiver.



Wear an anti-static wrist strap or take other suitable measures to prevent electrostatic discharge when handling this equipment.



Do not plug a phone jack connector in the RJ-45 port. This may damage this device.



Use only twisted-pair cables with RJ-45 connectors that conform to FCC standards.



The switch includes plug-in power supply (PSU) and fan tray modules that are installed into its chassis. All installed modules must have a matching airflow direction. That is, if the installed power modules have a front-to-back (F2B) airflow direction, all the installed fan tray modules must also have a F2B airflow direction.



Installing the switch in a rack requires two people. One person should position the switch in the rack, while the other secures it using the mounting screws.

Warnings and Cautionary Messages



Ce produit ne contient aucun composant susceptible d'être réparé par l'utilisateur.



L'installation et la dépose de l'unité ne doivent être réalisées que par du personnel qualifié.



Lorsque vous branchez cet appareil sur une prise électrique, la terre de la fiche à trois pôles doit être branchée sur une ligne mise à la terre pour écarter tout danger électrique.



Ce commutateur utilise des lasers pour transmettre des signaux via un câble de fibre optique. Ces lasers répondent aux exigences des produits laser de classe 1 et sont sans danger intrinsèque pour les yeux, sous réserve de leur utilisation normale. Vous ne devez cependant jamais regarder directement un port de transmission lorsque ce dernier est sous tension.



Lorsque vous utilisez un dispositif fibre de type SFP28/QSFP28, en ce qui concerne la sécurité, assurez-vous qu'il puisse fonctionner à une température inférieure à la température maximale de fonctionnement recommandée du produit. Utilisez également un émetteur-récepteur laser SFP28/ QSFP28 de classe 1 agréé.



La manipulation de cet équipement requiert le port d'un bracelet antistatique ou l'utilisation d'autres mesures pour éviter toute décharge électrostatique.



Ne branchez pas un connecteur téléphonique dans le port RJ-45. Vous risqueriez d'endommager l'appareil.



Ne branchez que des fils torsadés par paires conformes aux normes FCC sur les connecteurs RJ-45.



Le commutateur comprend des modules d'alimentation et de bac de ventilateurs installés sur son châssis. Tous les modules installés doivent avoir une direction de circulation d'air correspondante. C'est-à-dire que tous les modules doivent avoir la même direction de circulation d'air : avant vers arrière (F2B), ou arrière vers avant (B2F).



L'installation du commutateur dans un rack nécessite deux personnes. Une personne doit positionner le commutateur dans le rack, tandis que l'autre le fixe à l'aide des vis de montage.

1.3. Disclaimer

The information in this document is subject to change without notice. The manufacturer makes no representations or warranties with respect to the contents hereof and specifically disclaims any implied warranties of merchantability or fitness for any particular purpose. Furthermore, the manufacturer reserves the right to revise this publication and to make changes from time to time in the content hereof without obligation of the manufacturer to notify any person of such revision or changes.

For the latest information and updates please refer to www.netbergtw.com

All the illustrations in this technical guide are for reference only and are subject to change without prior notice.

Chapter 2. Hardware Installation

2.1. Package content

Package Contents:

- One Netberg Aurora Switch
- Two AC power cords.
- One RS-232-to-RJ45 console cable.
- One pair of frontal rack-mount brackets.
- Four rubber feet with adhesive patches.
- Eight Phillips-head frontal rack-mount bracket screws.



If any of the above mention items was not found inside the package contents of this switch or are damaged in any way, contact your reseller immediately.

2.2. Installation Guidelines

This section will discuss the hardware installation guidelines that administrators must follow in order to properly and safely install this switch into the appropriate environment.

2.3. Power and Battery Safety



Risk of explosion if battery is replaced by an incorrect type. Dispose of used batteries according to the battery manufacturer's instructions.



Risque d'explosion si la batterie est remplacée par un type incorrect. Éliminez les piles usagées conformément aux instructions.



Your switch uses a lithium battery, do not attempt to replace the battery yourself. Return the switch to the manufacturer for battery replacement.



Si votre commutateur utilise une batterie au lithium, n'essayez pas de la remplacer vous-même. Renvoyez le commutateur au fabricant pour le remplacement de la batterie.



Risk of Electrical Shock: To disconnect power, remove all power cords from the unit.



Risque de Choc Électrique: Pour débrancher, l'alimentation électrique, veuillez assurer tous les cables d'alimentation sont retirés de l'unité. === Power supply

Equipped with two supply modules, the switch can operate with either one or two power supply modules. If the switch uses two power supply modules, you can hot-swap one of the PSU during the operations.



One PSU is enough for a fully loaded chassis.

2.3.1. Replacing a PSU

1. Hold the PSU handle and press the release latch to unlock from the switch.
2. Pull the PSU module out of the switch.

Figure 2.1. Removing the PSU module

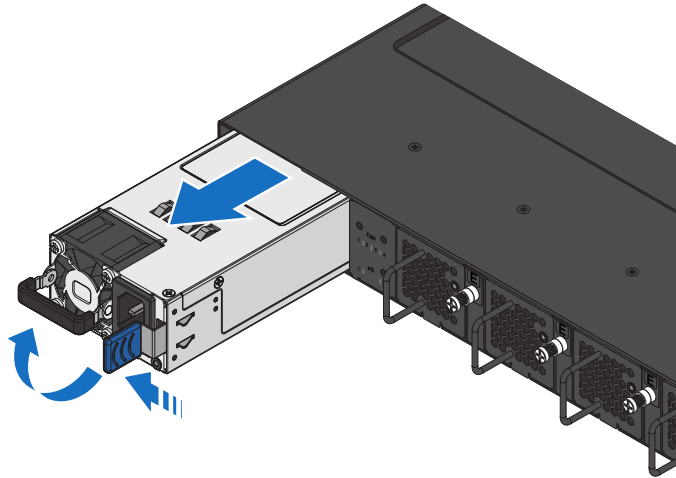

3. Align the PSU with the switch bay.
4. Slide the PSU into the switch and push until it is flush with the bay.

Figure 2.2. Inserting the PSU module

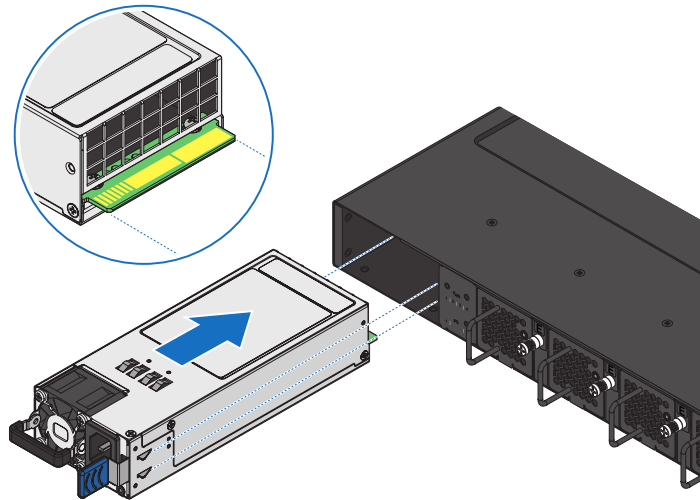

The AC power connector is a standard three-pronged connector. The switch automatically adjusts its power setting to any supply voltage in the range from 100-240 VAC at 50-60 Hz.

2.4. Grounding the Switch



This equipment must be grounded. Do not defeat the ground conductor or operate the equipment without a suitably installed ground conductor. Contact the appropriate electrical inspection authority or an electrician if you are uncertain that suitable grounding is available.

1. Ensure the rack is properly grounded and in compliance with local regulatory guidelines. Ensure that a good electrical connection to the grounding point exists. Remove any paint or material that may prevent good contact.
2. Remove the grounding screw from the switch.
3. Connect the screw to an 18 AWG minimum grounding wire (not provided), and connect it to the grounding screw on the switch.
4. Connect the other end of the wire to rack ground.

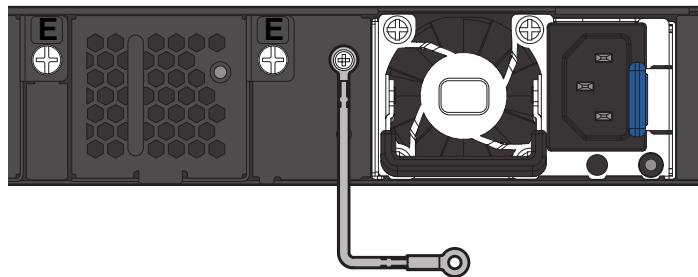

The chassis ground connection must not be removed unless all power supply connections have been disconnected.



Le raccordement à la terre ne doit pas être retiré sauf si toutes les connexions d'alimentation ont été débranchées.



The device must be installed in a restricted access location.



L'appareil doit être installé dans un emplacement à accès restreint. Il doit comporter une borne de terre de protection distincte sur le châssis, qui doit être connectée en permanence à la terre pour assurer une mise à la terre adéquate du châssis et protéger l'opérateur des risques électriques.

2.5. Connect the Power Cable

Connect one end of the AC power cord, included in the package, into the grounded electrical outlet at the site and insert the other end of the AC power cord into the AC power receptacle of the AC power supply module on the back panel of the switch. The switch will automatically adjust the voltage supplied to the voltage needed as this power supply supports any voltage power supply in the range from 100VAC to 240VAC at 50Hz to 60Hz.

The LED indicators on the front panel of the switch should lights green after power-on.

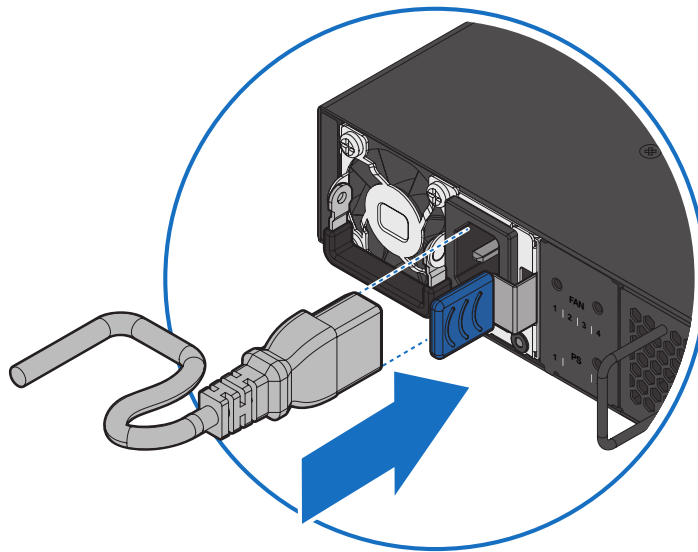

Use the AC power cord supplied with the switch. For International use, you may need to change the AC power cord. You must use power cord sets that have been approved for the socket type in your country.



Utilisez le cordon d'alimentation secteur fourni avec le commutateur. Pour une utilisation internationale, vous devrez peut-être changer le cordon d'alimentation. Vous devez utiliser des jeux de cordons d'alimentation approuvés pour le type de prise de votre pays.

2.6. Rack-mount Safety Precautions

For your protection, observe the following rack-mount safety precautions when setting up your equipment:

- **Elevated Operating Ambient** - If installed in a closed or multi-unit rack assembly, the operating ambient temperature of the rack environment may be greater than room ambient. Therefore, consideration should be given to installing the equipment in an environment compatible with the maximum ambient temperature (T_{ma}) specified by the manufacturer.
- **Reduced Air Flow** - Installation of the equipment in a rack should be such that the amount of air flow required for safe operation of the equipment is not compromised.
- **Mechanical Loading** - Mounting of the equipment in the rack should be such that a hazardous condition is not achieved due to uneven mechanical loading.
- **Circuit Overloading** - Consideration should be given to the connection of the equipment to the supply circuit and the effect that overloading of the circuits might have on overcurrent protection and supply wiring. Appropriate consideration of equipment nameplate ratings should be used when addressing this concern.
- **Reliable Earthing** - Reliable earthing of rack-mounted equipment should be maintained. Particular attention should be given to supply connections other than direct connections to the branch circuit (for example, use of power strips).
- For safety, equipment should always be loaded from the bottom up. That is, install the equipment that will be mounted in the lowest part of the rack first, then the next higher systems, etc.
- To prevent the rack from tipping during equipment installation, the anti-tilt bar on the rack must be deployed.
- The mounting brackets provided must be used to securely mount the device in a rack-mount unit.

2.7. Installation into a Rack

The switch can be mounted in a standard 19"(1U) rack using the provided mounting brackets. The following section will explain how to install the rack-mount brackets onto the switch and then mount the switch into a standard 1U rack-mount unit.

1. Use the supplied screws to attach a mounting bracket to each side of the Switch.
2. Align the holes in the mounting bracket with the holes in the rack.
3. Insert and tighten screws through each of the mounting brackets.

Figure 2.3. Front brackets installation

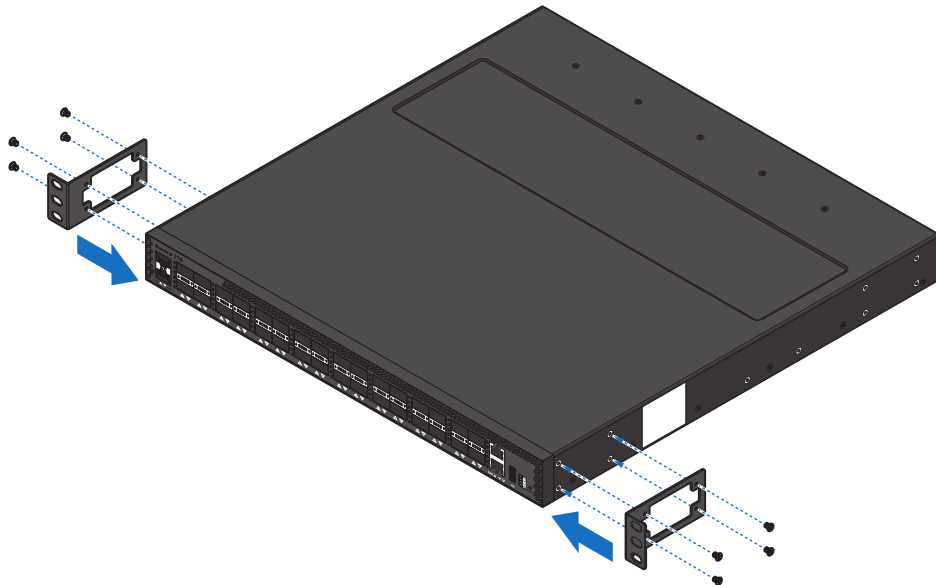

Two individuals are recommended to install the switch. One individual should position the switch in the rack, while the other secures it using the rack screws.



Deux personnes sont nécessaires pour installer un commutateur dans un bâti : La première personne va positionner le commutateur dans le bâti, la seconde va le fixer avec des vis de montage.

The switch can be installed directly on the rack without the use of the rail.

1. Align the built-in mounting ear to the rack holes.
2. Tighten the screws to secure the switch.

Figure 2.4. Rack installation

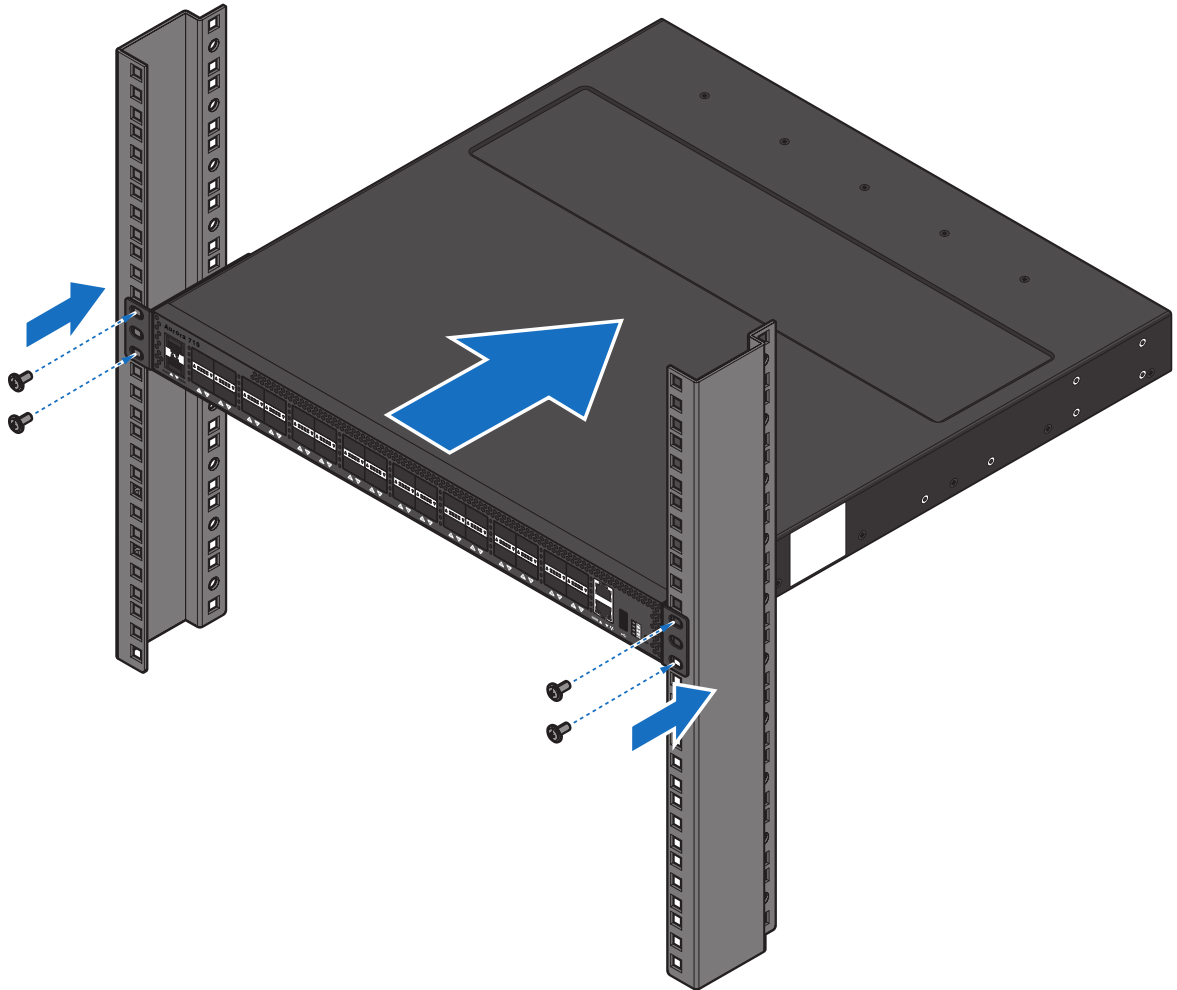

Illustrations are for reference purposes only. Actual cabinet posts may differ.

2.8. Installing Transceivers and cables into the Switch Ports

Figure 2.5. Transceivers and cables

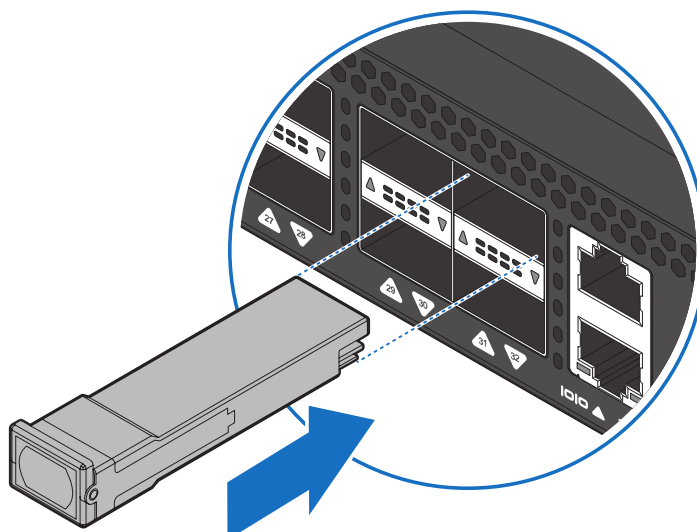

2.8.1. SFP+/SFP28 Port Connection (LC Type Connector)

The Small Form-Factor Pluggable Plus (SFP+) port is the second generation of the SFP interconnect system designed for 10Gb/s data rate. The SFP+ ports support 10-gigabit IEEE 802.3ae Ethernet for fiber mediums.

The Small Form-Factor Pluggable 28 (SFP28) port is the next generation of the SFP interconnect system designed for 25Gb/s data rate. The SFP28 ports enables error-free transmission of 25 Gb/s over 100 meters of OM4 multimode fiber.

The SFP+/SFP28 ports are numbered and have corresponding SFP port LEDs.

To install an SFP module, do the following:

1. Slide the SFP module into an SFP port.



Ensure the SFP module is positioned correctly before installing it into the port.

2. Push completely until the module locks into place.
3. Repeat the above procedures to install additional SFP+ modules.

The SFP port LED lights green when the network link is established.

2.8.2. QSFP+/QSFP28 Port Connection

QSFP+ (Quad SFP) ports which support 40G/per port or fan out to 4x10G by using the fan out DAC cable.

QSFP28 (Quad SFP) ports which support 100G/per port or fan out to 4x25G by using the fan out DAC cable.

1. Slide the QSFP module into a QSFP port.



Ensure the QSFP module is positioned correctly before installing it into the port.

2. Push completely until the module locks into place.
3. Repeat the above procedures to install additional QSFP modules.

The QSFP port LED lights green when the network link is established.

2.9. Fan Modules

The fan module is a field replaceable unit and can be replaced during operations as long as the remaining modules are installed and operating.

Replacing fan modules

1. Loosen the captive screw securing the fan module.
2. Pull out the fan module.
3. Align the fan module with the switch bay.
4. Slide the fan module into the switch and push until it is flush with the bay.
5. Secure the captive screw.

2.10. Console port

The console port is used for setting up and managing the switch via a connection to a console terminal or PC using a terminal emulation program. You can connect the switch to a terminal or PC using the supplied console cable (RJ-45 male to RS-232 female cable) for serial communication.

Below is the console cable wiring specification table:

Table 2.1. Console cable pin definition

RJ-45 Port of Switch	DB9 Female Port of PC	Abbreviation	Description
3	2	RD	Received Data
6	3	TD	Transmit Data
1	8	CTS	Clear To Send
8	7	RTS	Request To Send

Using the console port, you can perform the following:

- Configure, manage and monitor the switch using the CLI commands
- Manage and monitor network activity by Simple Network Management Protocol (SNMP) management
- Upgrade the firmware

To connect to the console, do the following:

1. Connect the RJ-45 connector to the console port (|o|o) of the switch.
2. Connect the RS-232 end to a terminal or PC.
3. Manage the switch using the CLI commands (refer to the CLI User Manual for more information).

The switch uses the following default settings:

- Baud rate: 115200
- Data width: 8 bits
- Parity: None
- Stop bits: 1
- Flow control: None

2.11. Verifying Switch Operation

Verify basic switch operation by checking the system LEDs.

When a NOS operating normally, the PSU1/PSU2, FAN, and SYS LEDs should all display green.

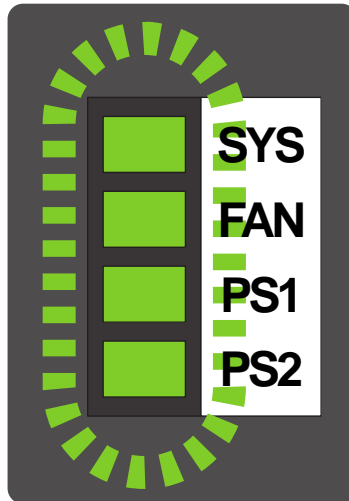

Chapter 3. Netberg Aurora 750 switch

The switch chassis is equipped with the following ports:

- 64x 100G QSFP28 ports supporting an optical transceiver, active optical cables, or direct-attached cable to connect the QSFP28 port to the hosts (uplink connections)
- 2 10G SFP+ ports from the CPU board
- 1 Management ports enables you to manage the switch operation using an RJ-45 Ethernet cable
- 1 RJ45 Console port to perform the initial configuration by connecting to a PC with the RJ-45 to DB-9 serial adapter cable
- 1 micro-USB console port to perform the initial configuration by connecting to a PC with the micro-USB to USB console cable
- 1 USB port to load the configuration files or OS from a USB storage device to the switch's flash/SSD memory

Figure 3.1. Aurora 750 front view

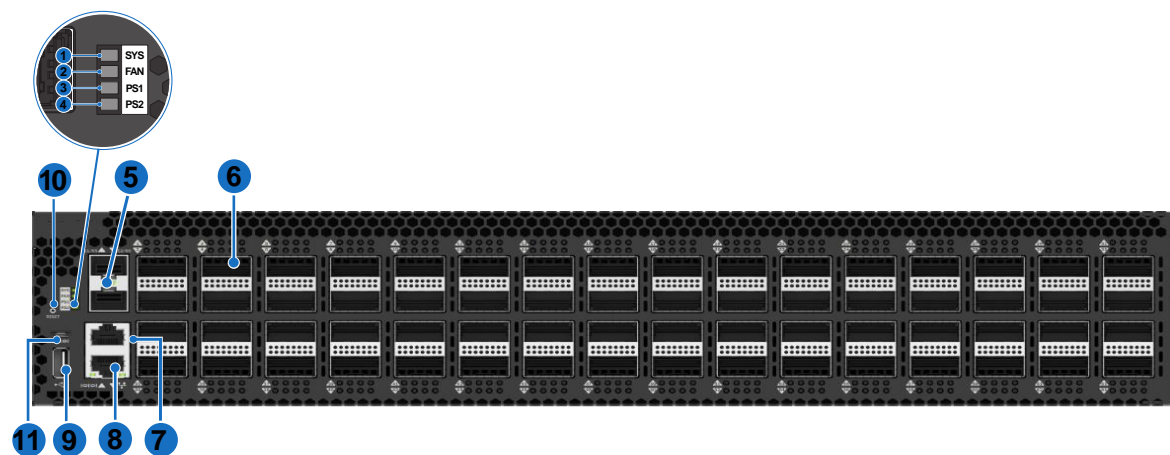

Table 3.1. Front panel features

No	Description	No	Description
1	Status LED	7	RJ45 console port
2	Fan LED	8	OOB management port
3	PSU1 status LED	9	USB port
4	PSU2 status LED	10	Reset button
5	2x 10G SFP+ ports	11	USB console port
6	64x 100G QSFP28 ports		

Figure 3.2. Aurora 750 rear view

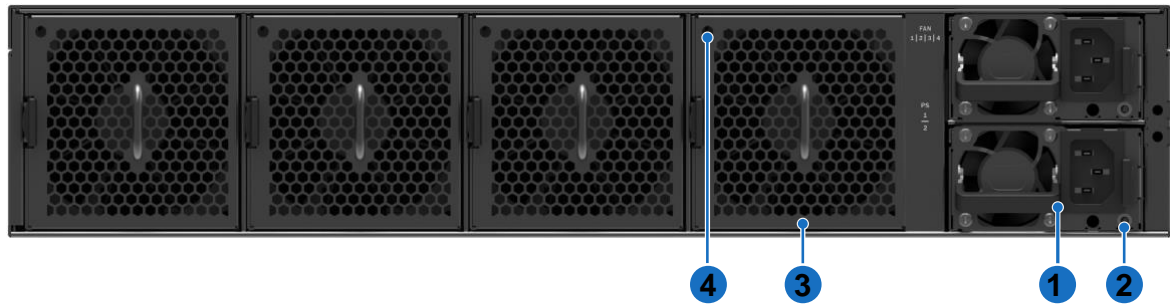

Table 3.2. Rear panel features

No	Description	No	Description
1	2x PSU modules	3	4x fan modules
2	PSU status LED	4	Fan status LED

3.1. Specification

System specification

Ports	<ul style="list-style-type: none"> • 64x 100/40GbE QSFP28 ports in 1 RU • Up to 256x 25/10G SFP28 port via break-out cables • 2x 10G SFP+ ports • 1x RJ-45 out-of-band (10/100/1000) management • 1x RJ-45 console (RS232) • 1x USB
Front IO	<ul style="list-style-type: none"> • Fan LED • System status LED • PSU1 status LED • PSU2 status LED • Reset button
Performance	<ul style="list-style-type: none"> • Switching silicon: 3.2Tbps Barefoot Tofino BFN-T10-064Q • Intel® Xeon™ Processor D-1257 • 16GB DDR4 ECC • 128GB SSD
Power	<ul style="list-style-type: none"> • 550W 1+1 RPSU 80+ Platinum <ul style="list-style-type: none"> • 100V-240V AC / 50-60Hz • 240V HVDC • 1200W 1+1 -40V~-60V DC RPSU (option) • Typical power - 730W • Maximum power - 830W
Cooling	<ul style="list-style-type: none"> • 4 N+1 redundant fans • Front-to-Back/Back-to-Front airflow
Dimensions (DxWxH)	428 x 440 x 44 mm
Environment	Operating temperature: 0~45°C
Operating humidity	20-95% maximum relative humidity (non-condensing)
Compatible NOS	<ul style="list-style-type: none"> • Open Network Linux

- SONiC

3.2. Supported Cables and Transceivers

See the following table for the list of supported cables and transceivers.

Distance	Description	Note
1m	40/100G Direct Attach Copper (DAC) cable	QSFP28 to QSFP28
	40/100G DAC Fan Out cable	QSFP28 to 4 SFP28
3m	40/100G Direct Attach Copper (DAC) cable	QSFP28 to QSFP28
	40/100G DAC Fan Out cable	QSFP28 to 4 SFP28
7-100m	100G Active Optical Cable (AOC)	QSFP28 to QSFP28 850 nm, MMF
	40/100G DAC Fan Out cable	QSFP28 to 4 SFP28
Up to 100m	100GBASE-SR4 QSFP28 Transceiver Optic (MPO)	QSFP28, 850nm, MMF
Up to 10km	100GBASE-LR4 QSFP28 Transceiver Optic (LC)	QSFP28, 1290-1310nm, SMF